

**PTO-AC CEII Working Group**

# **PTO-AC Guidelines for Handling CEII Materials and CEII Requests**

Effective Date: June 25, 2009

# Table of Contents

<b>1. Introduction .....</b>	<b>2</b>
<b>2. Acronyms and Definitions of Terms.....</b>	<b>2</b>
2.1. CEII Defined .....	2
2.2. Acronyms and Terms .....	4
<b>3. Determination of CEII Materials .....</b>	<b>5</b>
3.1. Recommended Methodology.....	5
3.2. Identifying CEII Materials.....	5
<b>4. Document Control .....</b>	<b>6</b>
4.1. CEII Delineation within Documents .....	6
4.2. Public Forums, Siting Councils, and Filings .....	7
4.3. E-mail Labeling and Electronic Information Protection.....	8
<b>5. Role of the CEII Coordinator .....</b>	<b>8</b>
<b>6. Release of CEII Materials.....</b>	<b>9</b>
<b>7. CEII Training .....</b>	<b>10</b>
<b>8. References.....</b>	<b>11</b>
<b>9. Summary of Changes .....</b>	<b>11</b>
<b>Attachment A, CEII Materials to Be Protected .....</b>	<b>12</b>
<b>Attachment B – Illustrative Examples of CEII .....</b>	<b>15</b>
<b>Attachment C, Sample CEII Request Form #1 .....</b>	<b>18</b>
<b>Attachment D, Sample CEII Request Form #2 .....</b>	<b>23</b>

## Review and Re-Adoption Requirements

This document will be reviewed periodically by the Participating Transmission Owners Administrative Committee (PTO-AC). The existing or revised document will be re-adopted by the PTO-AC and posted and/or distributed to staff and committees/working groups, as applicable.

## 1. **Introduction**

This guideline is intended to provide assistance to Participating Transmission Owners (PTO) in the administration and handling of Critical Energy Infrastructure Information (CEII). This guideline is intended as a suggested set of determining criteria and recommended components for the handling of CEII by a PTO. A PTO may utilize this guideline as it deems appropriate.

CEII refers to vital information that, if utilized by someone wishing to do harm, could provide sufficient detail to enable the disabling of the Bulk Power System, Critical Facilities, Critical Assets and Critical Cyber Assets.

This document will:

- Assist PTO personnel in determining the types of internal information that would be considered CEII.
- Provide guidance on document control for such information.
- Describe a process under which third parties may be granted access to CEII.

*NOTE: This procedure is not intended as a substitute for legal counsel. Each individual PTO should consult with its legal counsel when CEII is in question.*

While CEII designation is an important component of information protection, the Federal Energy Regulatory Commission (FERC) has also indicated that a Transmission Owner should “increase transparency and customer access to information.”<sup>1</sup> In addition, FERC has cautioned against the over-use of CEII.<sup>2</sup> Thus a PTO should avoid the over-use of CEII designation and restricted access to data that should otherwise be available for public scrutiny. It is also important that a PTO has consistent CEII policies and procedures to prevent confusion and contradiction among CEII requestors and providers.

## 2. **Acronyms and Definitions of Terms**

### 2.1. **CEII Defined**

To define CEII, it is important to understand the components of the term as it is defined by FERC. FERC defines CEII as “specific engineering, vulnerability, or detailed design information about proposed or existing *critical infrastructure* that: (1) relates details about the production, generation, transportation, transmission, or distribution of energy; (2) could be useful to a person in planning an attack on critical infrastructure; (3) is exempt from mandatory disclosure under the Freedom of Information Act, 5 U.S.C. 552 (2000); and (4) does not simply give the general location of the critical infrastructure.”<sup>3</sup>

---

<sup>1</sup> FERC Order 890 Fact Sheet

<sup>2</sup> FERC 18 CFR Part 388 (Docket No. RM06-23-000; Order No. 702) - Critical Energy Infrastructure Information (Issued October 30, 2007)

<sup>3</sup> 18 CFR Part 388 (Docket No. RM06-24-000; Order No. 683) – Critical Energy Infrastructure Information (Issued September 21, 2006)

To further understand CEII, a PTO should consider the following additional defined terms:

#### Critical Infrastructure

NERC defines Critical Infrastructure as “the Systems and Assets, whether physical or virtual, that are so vital to the United States that the incapacity or destruction of such systems or assets would have a debilitating impact on the security, national economic security, national public health or safety, or any combination of those matters.”<sup>4</sup> Systems, as defined in this procedure, refer to discrete protection, control, and communication systems.

#### Critical Assets

In addition, NERC identifies Critical Assets as “Facilities, systems, and equipment which, if destroyed, degraded, or otherwise rendered unavailable, would affect the reliability or operability of the *Bulk Electric System*.”<sup>5</sup>

#### Examples<sup>6</sup>:

- Function and physical location,
- Black start facilities,
- Extra high voltage (>230 kV) stations,
- Locations and responsibilities of control and operating entities, and
- Details of critical computer systems (e.g., operational systems such as Energy Management Systems (EMS), Supervisory Control and Data Acquisition (SCADA), digital control systems, their names and function, CAD/CAM facilities, network configuration and firewall schemes).

#### Bulk Electric System

NERC defines the Bulk Electric System as “As defined by the Regional Reliability Organization, the electrical generation resources, transmission lines, interconnections with neighboring systems, and associated equipment, generally operated at voltages of 100 kV or higher. Radial transmission facilities serving only load with one transmission source are generally not included in this definition.”<sup>7</sup>

#### Critical Facility

“Any facility or combination of facilities, if severely damaged or destroyed, would have a significant impact on the ability to serve large quantities of customers for an extended period of time, would have a detrimental impact to the reliability or operability of the energy grid, or would cause significant risk to public health and safety.”<sup>8</sup>

---

<sup>4</sup> USA Patriot Act of 2001 - H. R. 3162 (Sec. 1016. Critical infrastructures protection)

<sup>5</sup> NERC Glossary of Terms Used in Reliability Standards (4/20/2009)

<sup>6</sup> NERC Security Guidelines for the Electricity Sector, “Protecting Potentially Sensitive Information,” version 1.0 (June 14, 2002)

<sup>7</sup> NERC Glossary of Terms Used in Reliability Standards (4/20/2009)

<sup>8</sup> Security Guidelines for The Electricity Sector: Vulnerability and Risk Assessment, pg. 1 Applicability

## 2.2. Acronyms and Terms

Term	Definition
BES	.Bulk Electric System as defined by North American Electric Reliability Corporation (NERC).
BPS	Bulk Power System as defined by Northeast Power Coordinating Council (NPCC).
CCA	Critical Cyber Asset.
CEII	Critical Energy Infrastructure Information as defined by the Federal Energy Regulatory Commission (FERC).
CIP	Critical Infrastructure Protection: NERC standards created to enforce the protection of critical cyber assets associated with critical assets within the Bulk Power System.
Critical Assets	See Section 2.1.
Critical Cyber Assets	NERC defines Critical Cyber Assets as “those Cyber Assets essential to the reliable operation of Critical Assets.” <sup>9</sup>
Critical Infrastructure	See Section 2.1.
EMS	Energy Management System.
FERC	The Federal Energy Regulatory Commission, pursuant to the provisions set forth in the Federal Power Act, the Commission is responsible for regulating and overseeing the interstate transmission of electricity (specific powers are as set forth in the Federal Power Act).
FOIA	Freedom of Information Act.
ISO-NE	Independent System Operator New England: delegates and shares responsibility with the PTOs for many Transmission Operator (TOP) functions. While ISO-NE is accountable for certain types of reporting, it relies on the data from the PTOs.
NEPOOL	New England Power Pool.
NERC	North American Electric Reliability Corporation, through the establishment of Standards, ensures the reliability, adequacy and security of the nation’s Bulk Power System.
NDA	Non-disclosure agreement.
NPCC	Northeast Power Coordinating Council.

<sup>9</sup> NERC Glossary of Terms Used in Reliability Standards (4/20/2009)

PAC	Planning Advisory Committee.
PTO	Participating Transmission Owners.
RC	NEPOOL Reliability Committee.
SCADA	Supervisory Control and Data Acquisition.
SME	Subject Matter Expert.
TADS	Transmission Availability Data System.

### 3. **Determination of CEII Materials**

When determining if outgoing materials contain CEII, consider the following:

- “In general, narratives such as general descriptions of facilities and processes are public. However, if there are specific engineering, design or operational details of a critical infrastructure in narrative form, the information may be CEII or privileged.”<sup>10</sup>
- “CEII is limited and includes engineering, security, and detailed design information about proposed or existing critical infrastructure. Examples of CEII include detailed drawings and specifications, dam safety and technical reports, emergency action plans, hazard classification, construction design reports, public safety plans, and extreme event reports.”<sup>11</sup>

Please refer to Attachments A and B for specific examples of the types of materials (reports, diagrams, maps, studies, etc.) that should be considered for CEII labeling.

#### 3.1. **Recommended Methodology**

A PTO should designate material that has not yet been released to the public or filed with regulatory authorities, including any currently prepared materials for release, as CEII prior to release.

Once information is released to the public, or filed with regulatory authorities, information cannot be retroactively labeled as CEII. Thus, retroactively labeling previous files may not be necessary or appropriate for a PTO. However, a PTO may label materials as CEII for future releases, even if previously released to the public.

A PTO should consider the organizational value of labeling internal materials as verified CEII versus only outgoing materials as verified CEII. Once information has been deemed CEII, a PTO should include methodology within their protection processes to prevent future instances of that material from public distribution.

#### 3.2. **Identifying CEII Materials**

It is important for a PTO to have a method of determining if information is CEII and a plan to identify and label such, as needed.

---

<sup>10</sup> FERC Guidelines for Filing Critical Energy Infrastructure Information (CEII)

<sup>11</sup> FERC Guidelines for Filing Critical Energy Infrastructure Information (CEII)

In order to determine if materials are CEII, the PTO should consider the following aspects:

- Is the subject related to the Bulk Power System, Critical Facilities, Critical Assets, or Critical Cyber Assets?
- Could this material be used to harm the electric system infrastructure?
- How is the material (e.g., maps, diagrams, studies, applications) presented? Does it discuss contingencies and critical infrastructure weakness?

These questions may be answered through a methodology performed in a manner consistent within each PTO and among all PTOs. If the PTO determines that information is CEII, it should have a rationale for that determination, which provides defense against a legal or regulatory challenge.

#### 4. **Document Control**

A PTO should have a process in place to protect CEII materials. Before materials are released to the general public, or to any entity with the potential of being released to the public, the materials must be reviewed and processed accordingly. All applicable departments should be involved in this process.

For any documents being released by a PTO to those individuals who have signed NDAs, it is recommended that these materials be labeled as CEII on the cover page. In addition, a PTO may consider including a label on each page of a document.

Examples of CEII labels:

- Non-redacted document: *"This Report Contains Critical Energy Infrastructure Information (CEII) – Do Not Release Without Redacting."*
- For documents being redacted prior to public release: *"This document has been redacted for public use. Contact the document owner for further information."*
- For materials not containing CEII: *"This document has been reviewed and contains no CEII."*

A PTO may consider additional labels applicable to how the material is marked. Use of the phrase *"may contain CEII"* is not recommended due to the inexact nature of this designation.

##### 4.1. **CEII Delineation within Documents**

There are several methods to protect documents containing CEII,. One method is to remove CEII from within a study or report. By placing the removed CEII materials within appendices or attachments, the rest of the materials remain free of protected information.

When moving materials to an appendix or attachment disrupts the flow of information, a second method is to redact CEII within the document by utilizing black-out redaction for sentences, phrases, etc. (see Figure 1).

**Figure 1: Redacted CEII within a Document**

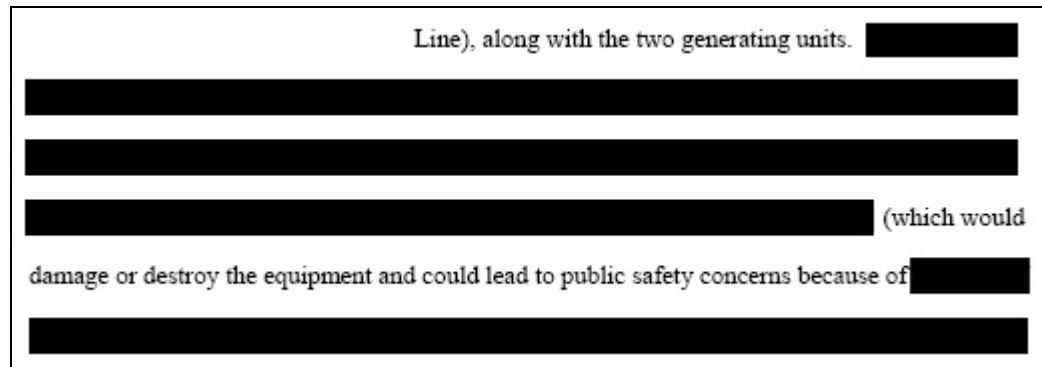

A non-redacted version may be marked to show the location of redacted portions within the public version of the document (see Figure 2).

**Figure 2: Non-Redacted Version with CEII Demarcation**

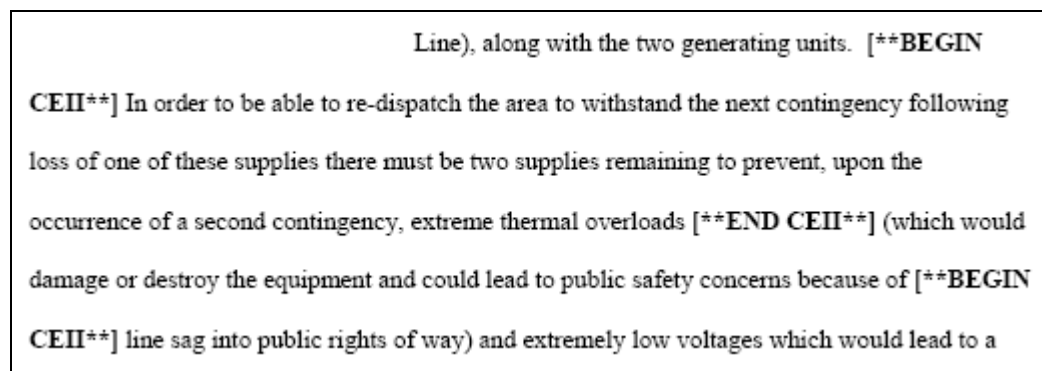

#### 4.2. Public Forums, Siting Councils, and Filings

Before making presentations in a public forum, it is recommended that all PTOs be cautious about the contents of their presentations. If a public forum requires the distribution of CEII materials, a PTO should have a process for identity verification (see Section 6 for more detail) and handling requests for access to CEII to ensure that recipients have been pre-screened and have signed the appropriate NDA.

It is important for each individual PTO to protect CEII materials being given out to public forums, siting councils, zoning boards, etc. Frequently, these State and local councils, through the Freedom of Information Act (FOIA), must make meeting materials and filings public. Due to this issue, a PTO should consider gaining a State or local level of protection for CEII.

The suggested methodology for PTOs to protect information presented to and/or filed with State and local venues is to seek a Protective Order for the proceeding, and provide two versions of materials to the council: a redacted public version and a confidential CEII version that can only be used by the council at such time as the Protective Order is granted.



#### 4.3. E-mail Labeling and Electronic Information Protection

While each PTO has individual information protection policies for confidential materials, it is important to update these policies, and any related training, to include information regarding protecting CEII.

If no policy exists relating to the protection of confidential information, a PTO may consider the following issues:

- E-mail transmission of protected materials:
  - Password protected Zip files
  - File and password sent separately
- Secure FTP transfer
  - FTP login and password sent separately
- Storage of CEII material on portable devices/media
  - Protect portable media through locked storage
  - Encryption of portable storage units such as laptops, PDAs, and flash drives
  - Keeping as much data on secure network rather than local computer hard drives
- Protect redacted materials in a manner that cannot be un-redacted, such as:
  - Scanning hard copies of redacted materials to PDF, rather than saving word processing files as PDF
  - Utilizing document protection and security functions within applications

#### 5. Role of the CEII Coordinator

Each PTO should designate a CEII Coordinator, who will be responsible for the administration of the CEII process for that organization. This includes CEII procedures, the proper labeling of CEII and administration of non-disclosure agreements as set forth in applicable CEII procedures.

The CEII Coordinator should assist with developing processes to identify and label information as CEII when that information is intended to be a component of a submission to a legitimate agency/regulator/entity that may request or require such information.

The CEII Coordinator should also ensure the PTO is prepared to handle requests for information from other members of the public. These requests may ask for information already submitted to ISO New England, FERC, or other regulators. The CEII Coordinator should oversee the creation of, and implementation of a process by which the PTO may determine whether the requestor has a legitimate reason to have the information and, if so, has signed the appropriate NDA.

CEII materials can be shared by a PTO with anyone who has a legitimate reason for having the information, so long as that person has been verified and has signed an NDA prohibiting the release of such information to the public. FERC has stated previously that nothing in its CEII regulations is intended to cause companies to withhold providing information to interested parties, and FERC encourages voluntary arrangements for sharing information.<sup>12</sup>

---

<sup>12</sup> FERC Order No. 643, Paragraph 16

The CEII Coordinator should assist with developing and maintaining policies and procedures to:

- Direct the process of identifying and marking CEII under the guidance provided in this Guideline and FERC regulations and orders.
- Coordinate administration of external requests for CEII, and the submission of CEII to ISO, FERC, siting councils, state regulatory commissions or other regulators, including NDA administration and/or a Protective Order.
- Identify the criteria to grant or deny requests for access to information containing CEII.

## 6. Release of CEII Materials

Material containing CEII may be released by a PTO to legitimate users outside of the organization or company. Examples of legitimate users include regulatory authorities, contractors, service providers, and affected parties in the general public. Information may be released:

- In response to an external request (i.e., through a public proceeding),
- In association with regulatory filings, and
- As a result of sharing information with service providers, contractors, and customers.

The PTO may need to perform a due diligence investigation regarding the legitimacy of a request or the legitimacy of the user and the user's need to know.

An overview of the recommended process for releasing CEII externally is illustrated in Figure 3.

**Figure 3: CEII Release Process**

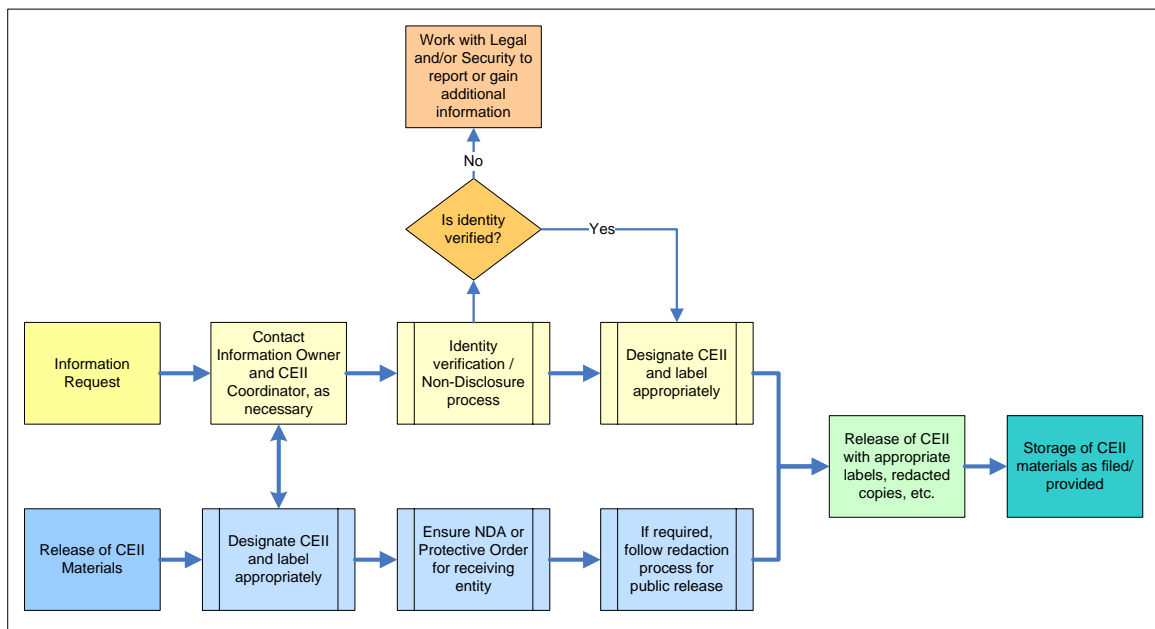

If the PTO identifies the need to release information externally, then the employee releasing CEII material should work with the information owner to verify whether the outgoing material contains CEII. This can be achieved by determining whether the material is marked as CEII or ensuring that the material is reviewed for possible CEII content.

If the PTO determines outgoing material contains CEII, then the PTO should have a process to ensure the recipient protects the information.

For external requests, such as those occurring through public proceedings, a PTO should use the following forms:

- CEII Request (see Attachments C and D for reference CEII request forms)
- Identity Verification (see Attachments C and D for reference CEII request forms)

A PTO may consider the following methods to verify the identity of CEII recipients:

- Internet search
- Calls to an employer to validate type of company and title of recipient
- Known professional contacts
- Background check release and execution

If a CEII recipient's identity has been misrepresented, a PTO should take measures, in coordination with internal security and legal departments, to ensure proper notification of appropriate legal authorities.

After legitimacy of need and the requestor's identity have been verified, the PTO may then use the PTO Non-Disclosure Agreement (see Attachments C and D). By signing the NDA, the CEII recipient should agree to comply with all limitations on the use of CEII.

To release CEII material to regulatory agencies, those agencies should have in place existing methods of securing information within proceedings, such as a Protective Order. A PTO may seek a Protective Order to ensure the confidential treatment of CEII within the proceeding. In this instance, a PTO should expect to provide both public (redacted) and complete versions of all materials presented, thus allowing the agency to disclose non-protected information to the public.

A PTO should have a records management method to store items such as material released, CEII request forms, signed NDAs, identity verification forms, and Protective Orders.

## **7. CEII Training**

A PTO should provide training within the organization, such that personnel understand the basics of identifying and handling CEII. While each PTO will have its unique training program, the program should include, at a minimum:

- Definition and examples of CEII
- Criteria for CEII
- Labeling, redacting, and releasing CEII
- References for CEII guidance, such as FERC publications and internal resources
- Identification of the CEII Coordinator and the Coordinator's responsibilities within an organization
- Contact information for the CEII Coordinator

## 8. References

- FERC 18 CFR Parts 4, 16, 141 and 157 (Docket No. RM03-6-000; Order No. 643) – Amendments to Conform Regulations With Order No. 630 (Critical Energy Infrastructure Information Final Rule – Issued July 23, 2003)
- 18 CFR Part 388 (Docket No. RM06-24-000; Order No. 683) – Critical Energy Infrastructure Information (Issued September 21, 2006)
- FERC 18 CFR Part 388 (Docket No. RM06-24-001; Order No. 683-A) – Critical Energy Infrastructure Information (April 9, 2007)
- FERC 18 CFR Part 388 (Docket No. RM06-23-000; Order No. 702) - Critical Energy Infrastructure Information (Issued October 30, 2007)
- FERC Guidelines for Filing Critical Energy Infrastructure Information (CEII) – Available from FERC website
- FERC Order 890, “Preventing Undue Discrimination and Preference in Transmission Service” (February 16, 2007)
- FERC Order 890 Fact Sheet
- Comments from NERC on FERC Rule Regarding Critical Energy Infrastructure Information (Docket No. RM02-4-000, Docket No. PL02-1-000)
- NERC Glossary of Terms Used in Reliability Standards (4/20/2009)
- NERC Security Guidelines for the Electricity Sector (version 1.0, June 14, 2002):  
“Protecting Potentially Sensitive Information,”  
<http://www.esisac.com/publicdocs/Guides/V1-SensitiveData.pdf>  
“Vulnerability and Risk Assessment, pg. 1 Applicability” (version 1.0, June 14, 2002)  
<http://www.esisac.com/publicdocs/Guides/V1-VulnerabilityAssessment.pdf>
- NPCC Document A-7, “NPCC Glossary of Terms” (July 17, 2007)
- NPCC Document A-10, “Classification of Bulk Power System Elements” (April 28, 2007)
- NPCC Document A-3, “Emergency Operation Criteria” (August 31, 2004)
- New England Participating Transmission Owner (PTO) Procedure for Disclosure of Critical Energy Infrastructure Information (CEII)
- USA Patriot Act of 2001 - H.R. 3162 (Sec. 1016. Critical infrastructures protection)

## 9. Summary of Changes

### Revision 0

None – This procedure is the original issue.

## Attachment A, CEII Materials to Be Protected

The following information was developed through the cooperation of a PTO-AC working group and representatives from ISO-NE.

In addition, please refer to NERC Security Guidelines for the Electricity Sector, "Protecting Potentially Sensitive Information," version 1.0 (June 14, 2002) for determining if materials should be treated as CEII.

### Maps/diagrams

What types of information require CEII labeling for maps/diagrams?

- Detailed representation of transmission components containing elements of Bulk Power System, Critical Facilities, Critical Assets and Critical Cyber Assets (i.e., Breaker/transformer, with ratings, connections, etc.)

*Note: Some distribution and generation interconnection diagrams may contain Bulk Power System, Critical Facilities, Critical Assets and Critical Cyber Assets information.*

- Depiction of line ratings or transfer capability or bottlenecks for any Bulk Power System element or resource components: i.e., the output of analyses that illustrates or infers Bulk Power System problems under contingencies, such as might be used to technically substantiate needs for system improvements
- Maps, diagrams, and system elements related to nuclear facilities

*Note: Maps that might otherwise appear to be innocuous may contain legends that provide CEII-level detail.*

What types of maps/diagrams can be made public?

- One-line type representation of transmission lines (simple schematic one-lines, not the output of PSS/E or similar analysis software) that may include:
  - Voltage level(s): i.e., the nominal conductor ratings, not voltage problems
  - TO territory or ownership
- Geographic maps without technical details

Examples:

#### **CEII marking required:**

- Northeast 345kV system diagram (includes bus detail)
- Diagrams/maps submitted as part of the modeling info (assumes level of detail is such that it can be utilized for modeling purposes, but not known contingencies that would aid modeling of system problems)
- New England Regional System Plan (RSP) – RSP06 Northern and Southern Area Maps
- ISO-NE Detailed Price Node (PNode) diagram
  - Detailed diagram (marked as CEII because it contains detail of each substation with breaker, transformer, bus conditions, and generator location)

**Public** (no CEII demarcation):

- New England one-line diagram (no detail that requires protection)

- New England geographic and/or Geographic Transmission Map including topological transmission maps (not enough detail)
  - Exception for maps with generator type indicated (such as nuclear in the above list)
- ISO-NE General PNode diagram:
  - Versions of PNode diagrams without bus / breaker /transformer detail listed (similar to a basic one-line diagram)

### **Reports, data, etc.**

*Note: Reports that have sections designated as CEII should be labeled as containing CEII.*

What aspects require CEII demarcation for this category?

- The inclusion of any of the protected maps from above in report
- Detailed descriptions of Bulk Power System components or protective schemes (i.e., relay and protection info, special protection system detail, substation design detail)
- Description of a specific Bulk Power System weakness or vulnerability
  - “Needs” description specifying the conditions or contingencies that lead to the need
  - Description of a justification for an alternative (indirect reference to weakness or vulnerability)
  - Market performance language that indirectly describes or relates to a specific weakness or vulnerability in the bulk power system
  - Powerflow cause and effect description
  - Powerflow data

Examples:

#### **CEII marking required:**

- Load Power Factor Studies and Audit Results
- Sections 2, 3 and 6 of Form 715
- Portions of Capacity, Energy, Loads, and Transmission (CELT) report that include technical detail as noted above
- Detailed System disturbance/event follow-up/Blackout report (describes vulnerability)
- Market/Reliability event related to a system disturbance (describes vulnerability)
- Annual Maintenance Schedule (can be used to derive vulnerability as it incorporates forecast of capacity shortcoming)
- Transmission Maintenance Schedule (can be used to derive vulnerability)
- Reliability Agreement info (i.e., Southwest CT Gap info – depicts needs)
- Study analysis (depicts needs or vulnerability):
  - Maine Power Reliability Program (MPRP)
  - Southeastern Massachusetts Reliability Region (SEMA)
  - Millstone Severe Line Outage Detector (SLOD) Special Protection System (SPS) Stability Report

- Data/info submittals (detailed engineering data):
  - NX-9
  - NX-11
  - I.3.9

**Public** (no CEII demarcation):

- Generic Interface Constraints spreadsheet
- Claimed Capability Report (lacks detail)
- Installed Capacity Requirement (ICR) report
- Financial Transmission Rights (FTR) related reports
- Contingency definitions spreadsheet (detailed, yet may lack value unless coupled with results – case by case basis)
- Line and ZBR Definitions spreadsheet (detailed, yet may lack value unless coupled with results – case by case basis)
- Monthly Interface Limits spreadsheet (only depicts limits with no detail)

**Critical Infrastructure Protection**

Any materials classified as protected CIP information through the PTO's CIP methodologies and processes are CEII, but are subject to specific handling restrictions as detailed in the NERC CIP Standard Requirements.

## Attachment B – Illustrative Examples of CEII

Please note: the information in this section has been changed only to exclude specific company information.

The following examples refer to specific instances in which CEII has been redacted for public release.

### Example 1

- One-line diagrams depicting the results of thermal analysis showing overvoltage:

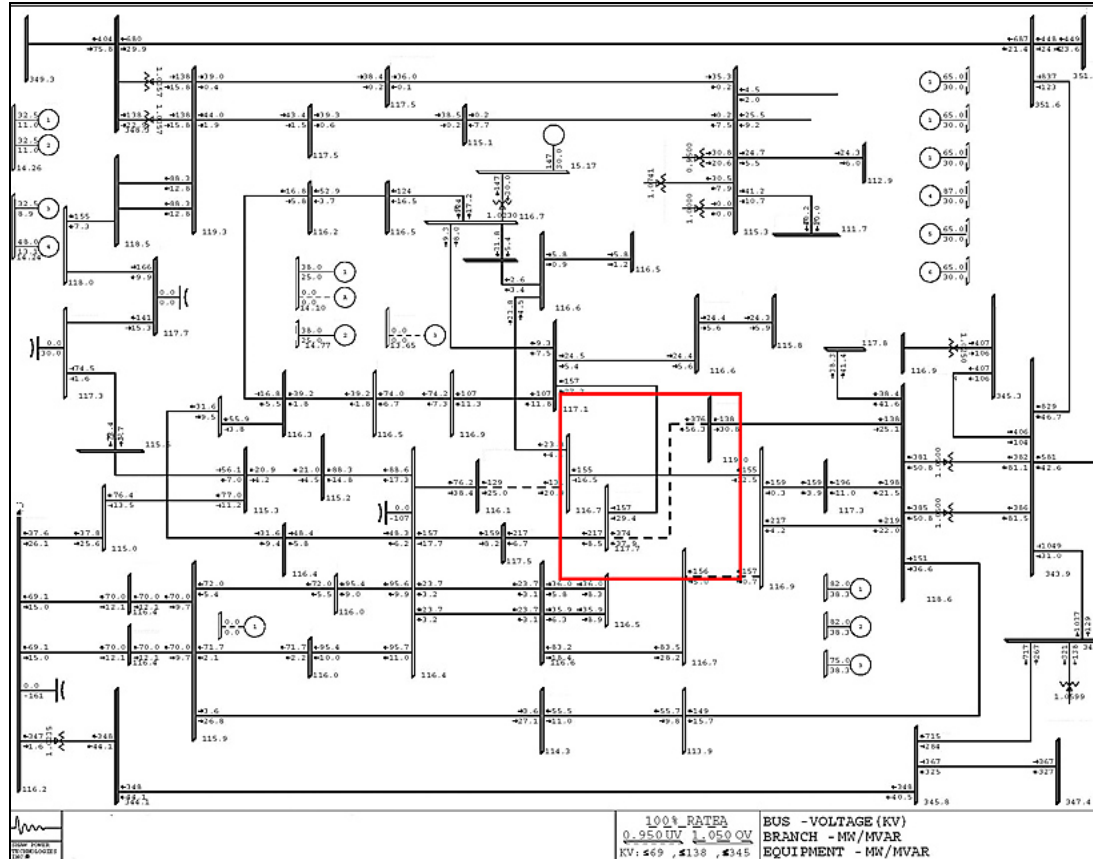



**Example 2**

- Detailed one-lines depicting specific equipment, location, ratings, overloads, and/or contingencies:

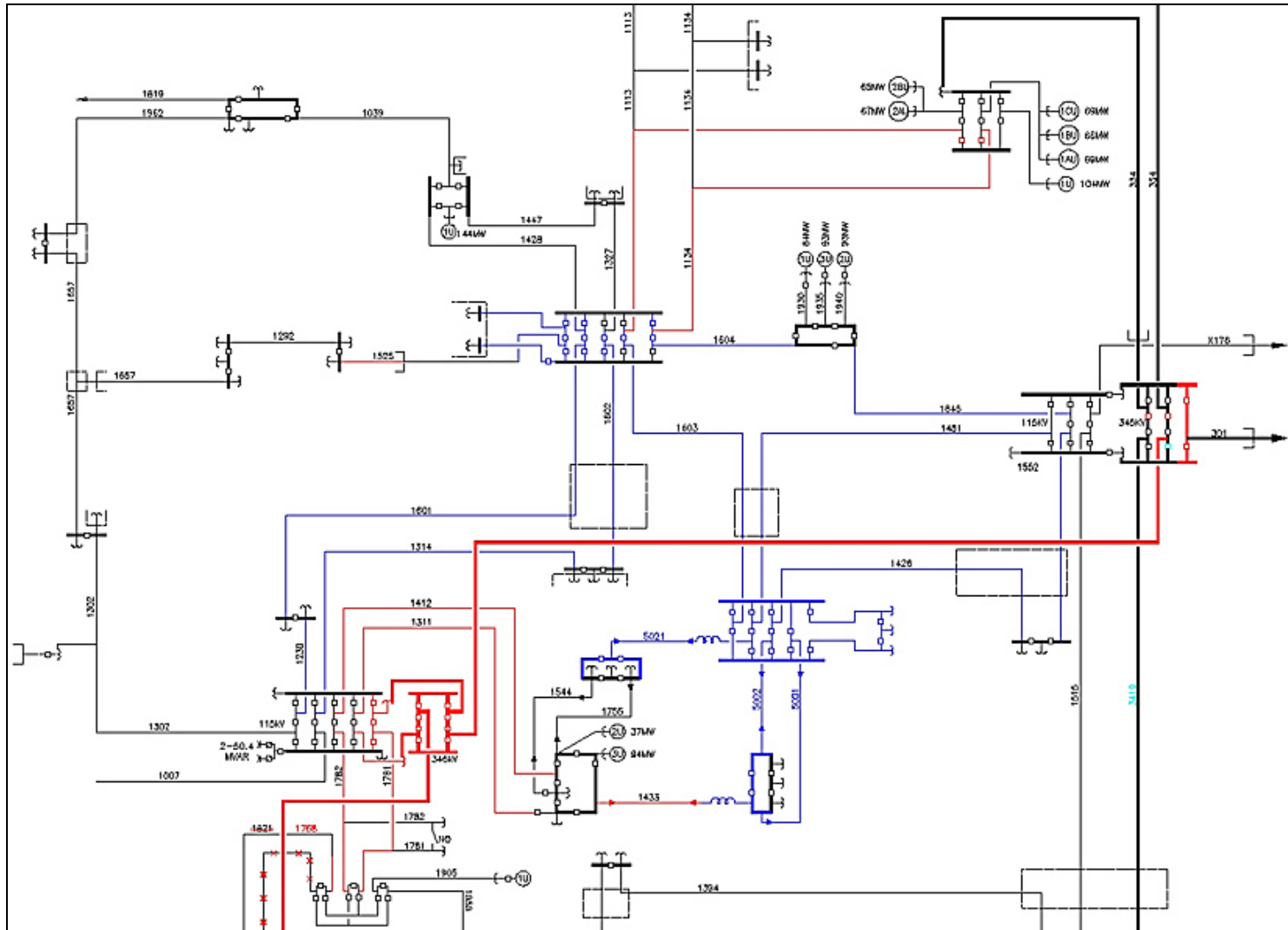

**Example 3**

- Detailed descriptions of contingencies and system weaknesses, such as those within a project petition or application:

Note: Items in *RED ITALIC TEXT* have been replaced with generic information.

**PROJECT BACKGROUND**

This proposed Project resolves future contingency overloads on the existing transmission system that could occur if both the 310 and the 368 circuits were out-of-service together. Each is a 345-kV circuit.

A comprehensive 10-year load-flow analysis conducted by *COMPANY NAME* and *ISO* revealed that during times when *STATE* imports are high and both *GENERATION* are on line, loss of both the *CIRCUIT #* circuit from *SPECIFIC SUBSTATION AND LOCATION #1* to *SPECIFIC SUBSTATION AND LOCATION #2* and the *CIRCUIT #* circuit from *GENERATION* to *SPECIFIC SUBSTATION AND LOCATION #2* would cause other 345-kV lines to be loaded above their Long Time Emergency (“LTE”) ratings.

The table below shows the contingency load-flow results that would not satisfy *RRO*, *ERO*, *ISO* and *COMPANY* reliability standards, when the *CIRCUIT #* and *CIRCUIT #* circuits are out-of-service at the same time.

<u>Monitored Line</u>			<u>Flow before second circuit trips</u>	<u>Flow after second circuit trips</u>	<u>LTE Rating</u>	<u>% rating</u>
From Bus	To Bus	Circuit #	MVA	MVA	MVA	
<i>Specified From Bus</i>	<i>Specified To Bus</i>	<i>Circuit #</i>	1116.8	2032.9	1793	110
<i>Specified From Bus</i>	<i>Specified To Bus</i>	<i>Circuit #</i>	1158.3	2117.1	1912	108
<i>Specified From Bus</i>	<i>Specified To Bus</i>	<i>Circuit #</i>	1195.9	2114.2	1912	107
<i>Specified From Bus</i>	<i>Specified To Bus</i>	<i>Circuit #</i>	1148.5	1920.2	1912	97

## Attachment C, Sample CEII Request Form #1

### CRITICAL ENERGY INFRASTRUCTURE INFORMATION (“CEII”) REQUEST INSTRUCTIONS

The attached form is intended to facilitate your request for information that is classified by COMPANY as CEII. For your information, the Federal Energy Regulatory Commission (“FERC”) has defined CEII as “specific engineering, vulnerability, or detailed design information about proposed or existing critical infrastructure that: (1) relates details about the production, generation, transportation, transmission, or distribution of energy; (2) could be useful to a person in planning an attack on critical infrastructure; (3) is exempt from mandatory disclosure under the Freedom of Information Act, 5 U.S.C. 552 (2000); and (4) does not simply give the general location of the critical infrastructure.”

The attached form is intended to cover discrete requests for information, including participation in limited purpose working groups (e.g., formed to complete a transmission study). For access to secure portions of COMPANY’s website, like those for the COMMITTEE and the COMMITTEE, please refer to those sections of the website.

In order for COMPANY to consider your request, you must complete, sign, date and return the following forms:

1. CEII Request Form
2. Non-Disclosure Agreement (unless you are employed by a Governance or Market Participant and registered as a “Person” under that Participant in COMPANY’s Customer and Asset Management System or you are an employee of FERC, in which cases the COMPANY Information Policy applies)

Please understand that changes to these documents are not permissible due to the volume of requests we receive and to ensure that all entities are treated fairly and equally.

Each of these forms requires you to identify yourself as: a registered employee of a Governance or Market Participant; an employee of another COMPANY TYPE or RTO; a state agency employee; a federal agency employee; an employee of an electric reliability organization or regional entity; an employee of a transmission owner in another region; a consultant for one of the foregoing entities; or “other.” Note that it is less likely that COMPANY will grant the request of an individual in the latter category, given the sensitive nature of CEII.

Please note that these requests are individual and each person within an entity or organization who will access the CEII must complete these forms.

Finally, note that COMPANY will not act upon your request until these steps are completed. When these steps are completed and reviewed, COMPANY will forward the relevant information to you.

**PLEASE BE ADVISED THAT THE DISCLOSURE OF CEII TO YOU IS DISCRETIONARY, AND COMPANY MAY REJECT YOUR REQUEST FOR ANY REASON.**

Any questions regarding this CEII Request Form may be directed to Customer Services at 413-540-4220. All correspondence, including the completed forms, should be mailed or faxed to COMPANY, Attention: ADDRESS.

### CRITICAL ENERGY INFRASTRUCTURE INFORMATION (“CEII”) REQUEST FORM

1. This form must be accompanied by an original signed Non-Disclosure Agreement, unless you are a registered employee of a Governance Participant (as indicated below) or FERC, in which case the COMPANY Information Policy applies. If you have already signed a CEII Non-Disclosure Agreement, please provide the date: \_\_\_\_\_
2. The undersigned requests the following information [describe in detail]:

- 
- 
3. The undersigned is:
- employed by a Governance Participant or Market Participant and registered as a “Person” under that Participant in COMPANY’s Customer and Asset Management System
  - an employee of another independent system operator or regional transmission organization in North America
  - a state agency employee
  - a federal agency employee
  - an employee of the electricity reliability organization or regional entity
  - an employee of a transmission owner in another control area
  - a consultant of one of the entities listed above who has been retained to provide advice regarding the matter described in no. 5 below
  - other (note that COMPANY is less likely to grant the request of persons in this category)
4. Give the name of your employer and your title: \_\_\_\_\_
5. The undersigned represents warrants and agrees that the information is to be used solely for the following purpose [describe in detail]: \_\_\_\_\_
6. If you are a consultant, provide the name and contact information of an individual at the organization that has retained you so that we may verify your role: \_\_\_\_\_
7. If you are in the “other” category, please provide the name and contact information of an individual at COMPANY or one of the entities listed in no. 3 who may verify the legitimacy of your request: \_\_\_\_\_

I acknowledge that the foregoing is true and accurate, and agree to give COMPANY immediate notice if any of the foregoing is no longer true. I also consent to COMPANY sharing the fact that this request has been made and/or granted, and agree that COMPANY shall have no liability to me in connection with this request.

Signature: \_\_\_\_\_ Name (please print): \_\_\_\_\_

Organization: \_\_\_\_\_ Business Address: \_\_\_\_\_

Email: \_\_\_\_\_ Phone: \_\_\_\_\_

Fax: \_\_\_\_\_ Date: \_\_\_\_\_

#### CEII NON-DISCLOSURE AGREEMENT

This CEII NON-DISCLOSURE AGREEMENT (the “Agreement”) is made by the undersigned (the “Recipient”) in favor of COMPANY (“COMPANY”), with its primary address located at One Sullivan Road, Holyoke, MA 01040.

WHEREAS, the Recipient has requested that COMPANY disclose to the Recipient certain information, all or a portion of which may be classified by COMPANY as Critical Energy Infrastructure Information; and

WHEREAS, the Federal Energy Regulatory Commission has defined Critical Energy Infrastructure Information as “specific engineering, vulnerability, or detailed design information about proposed or existing critical infrastructure that: (1) relates details about the production, generation, transportation, transmission, or distribution of energy; (2) could be useful to a person in planning an attack on critical infrastructure; (3) is exempt from mandatory disclosure under the Freedom of Information Act, 5 U.S.C. 552 (2000); and (4) does not simply give the general location of the critical infrastructure”;

NOW, THEREFORE, for good and valuable consideration, the receipt and adequacy of which are hereby acknowledged, the Recipient agrees as follows:

1. Definition of CEII. For purposes of this Agreement, “Critical Energy Infrastructure Information” or “CEII” shall mean: (i) all information designated as such by COMPANY, whether furnished before or after the date hereof, whether oral, written or recorded/electronic, and regardless of the manner in which it is furnished; and (ii) all reports, summaries, compilations, analyses, notes or other information which contain such information.

2. Use and Protection of CEII.

(a) All CEII shall be maintained by Recipient in a secure place. Recipients may make copies of CEII, but such copies become CEII and subject to these same procedures. Recipients may make notes of CEII, which shall be treated as CEII if they contain CEII.

(b) Although a Recipient of CEII may use CEII as foundation for advice provided to his or her employer or clients, s/he may only discuss CEII with or disclose CEII to another Recipient of the identical CEII. A Recipient may check with COMPANY to determine whether another individual is a Recipient of the identical CEII.

(c) A Recipient will not knowingly use CEII directly or indirectly for an illegal or non-legitimate purpose.

(d) In the event that the Recipient is required to disclose CEII by subpoena, law or other directive of a court, administrative agency or arbitration panel, the Recipient hereby agrees to provide COMPANY with prompt notice of such request or requirement in order to enable COMPANY to (i) seek an appropriate protective order or other remedy, (ii) consult with the Recipient with respect to taking steps to resist or narrow the scope of such request or legal process, or (iii) waive compliance, in whole or in part, with the terms of this Agreement. In the event that such protective order or other remedy is not obtained, or COMPANY waives compliance with the provisions hereof, the Recipient hereby agrees to furnish only that portion of the CEII which the Recipient’s counsel advises is legally required and to exercise best efforts to obtain assurance that confidential treatment will be accorded such CEII.

3. Return of CEII. In the event that COMPANY, in its sole discretion, so requests, the Recipient will promptly deliver to COMPANY all CEII, including all copies, reproductions, summaries, compilations, analyses or extracts thereof.

4. Change in Status. If the information provided to COMPANY in Recipient’s request for CEII changes (e.g., Recipient leaves his or her employ, the consulting engagement cited in the request is terminated, Recipient’s employer is no longer a Governance Participant) s/he must inform COMPANY

immediately in writing at the address first given above (Attention: Customer Services). COMPANY may require the return of the CEII or its destruction.

5. CEII "on Loan". Information provided pursuant to this Agreement is deemed to be on loan and must be returned to COMPANY upon request. If the Recipient is an employee of a federal or State agency, s/he must note that the information is not the property of the agency and is not subject to Freedom of Information/Public Records acts or similar statutes.

6. No Warranty. The CEII is provided "as is" with all faults. In no event shall COMPANY be liable for the accuracy or completeness of the CEII. COMPANY shall not have liability to the Recipient, or any other person or entity, for the Recipient's use of any CEII disclosed pursuant to this Agreement.

7. Equitable Relief; Audit. Without prejudice to the rights and remedies otherwise available to COMPANY, COMPANY shall be entitled to seek equitable relief by way of injunction or otherwise if the Recipient breaches or threatens to breach any of the provisions of this Agreement. COMPANY may audit the Recipient's compliance with this Agreement.

8. Survival. The Recipient remains bound by these provisions unless COMPANY rescinds the CEII designation.

9. No Waiver. The Recipient understands and agrees that no failure or delay by COMPANY in exercising any right, power or privilege hereunder shall operate as a waiver thereof, nor shall any single or partial exercise thereof preclude any other or further exercise thereof or the exercise of any right, power or privilege hereunder.

10. Governing Law. This Agreement shall be governed by and construed in accordance with the laws of the Commonwealth of Massachusetts without regard to its conflicts of laws principles.

11. Assignment Prohibited. Any assignment of the Recipient's rights, obligations or duties under this Agreement without COMPANY's prior written consent shall be void.

12. Entire Agreement. This Agreement contains the entire agreement between the parties concerning the protection of the CEII, and no modification of this Agreement or waiver of the terms and conditions hereof shall be binding upon the parties, unless approved in writing by each of them.

13. Severability. If any provision or provisions of this Agreement shall be held to be invalid, illegal or unenforceable, the validity, legality and enforceability of the remaining provisions shall not in any way be affected or impaired thereby.

IN WITNESS WHEREOF, the Recipient has executed this CEII Non-Disclosure Agreement as of the date set forth below.

Signature: \_\_\_\_\_

Name (please print): \_\_\_\_\_

Date:

Organization:

Address:

## Attachment D, Sample CEII Request Form #2

### CEII NON-DISCLOSURE AGREEMENT

This CEII NON-DISCLOSURE AGREEMENT (the “Agreement”) is made by the undersigned (the “Recipient”) in favor of COMPANY as agent for one or more of its affiliates (collectively, the Company).

WHEREAS, the Recipient has requested that the Company disclose to the Recipient certain information, all or a portion of which has been classified as Critical Energy Infrastructure Information; and

WHEREAS, the Federal Energy Regulatory Commission has defined Critical Energy Infrastructure Information as “specific engineering, vulnerability, or detailed design information about proposed or existing critical infrastructure that: (1) relates details about the production, generation, transportation, transmission, or distribution of energy; (2) could be useful to a person in planning an attack on critical infrastructure; (3) is exempt from mandatory disclosure under the Freedom of Information Act, 5 U.S.C. 552 (2000); and (4) does not simply give the general location of the critical infrastructure”;

NOW, THEREFORE, for good and valuable consideration, the receipt and adequacy of which are hereby acknowledged, the Recipient agrees as follows:

1. Definition of CEII. For purposes of this Agreement, “Critical Energy Infrastructure Information” or “CEII” shall mean: (i) all information designated as such by FERC, or the Company, whether furnished before or after the date hereof, whether oral, written or recorded/electronic, and regardless of the manner in which it is furnished; and (ii) all reports, summaries, compilations, analyses, notes or other information which contain such information.

2. Use and Protection of CEII.

(a) All CEII shall be maintained by Recipient in a secure place. Recipients may make copies of CEII, but such copies become CEII and subject to these same procedures. Recipients may make notes of CEII, which shall be treated as CEII if they contain CEII.

(b) Although a Recipient of CEII may use CEII as foundation for advice provided to his or her employer or clients, s/he may only discuss CEII with or disclose CEII to another Recipient of the identical CEII. A Recipient may check with the Company to determine whether another individual is a Recipient of the identical CEII.

(c) A Recipient will not knowingly use CEII directly or indirectly for an illegal or non-legitimate purpose.

(d) In the event that the Recipient is required to disclose CEII by subpoena, law or other directive of a court, administrative agency or arbitration panel, the Recipient hereby agrees to provide the Company with prompt notice of such request or requirement in order to enable the Company to (i) seek an appropriate protective order or other remedy, (ii) consult with the Recipient with respect to taking steps to resist or narrow the scope of such request or legal process, or (iii) waive compliance, in whole or in part, with the terms of this Agreement. In the event that such protective order or other remedy is not obtained, or the Company waives compliance with the provisions hereof, the Recipient hereby agrees to furnish



only that portion of the CEII which the Recipient's counsel advises is legally required and to exercise best efforts to obtain assurance that confidential treatment will be accorded such CEII.

3. Return of CEII. In the event that the Company, in its sole discretion, so requests, the Recipient will promptly deliver to the Company all CEII, including all copies, reproductions, summaries, compilations, analyses or extracts thereof.

4. Change in Status. If the Recipient ceases to be a party or intervenor in the siting proceeding to which the CEII provided hereunder relates, the Company may require the return of the CEII or its destruction.

5. CEII "on Loan". Information provided pursuant to this Agreement is deemed to be on loan and must be returned to the Company upon request. If the Recipient is an employee of a federal or State agency, s/he must note that the information is not the property of the agency and is not subject to Freedom of Information/Public Records acts or similar statutes.

6. No Warranty. The CEII is provided "as is" with all faults. In no event shall the Company be liable for the accuracy or completeness of the CEII. The Company shall not have liability to the Recipient, or any other person or entity, for the Recipient's use of any CEII disclosed pursuant to this Agreement.

7. Equitable Relief; Audit. Without prejudice to the rights and remedies otherwise available to the Company, the Company shall be entitled to seek equitable relief by way of injunction or otherwise if the Recipient breaches or threatens to breach any of the provisions of this Agreement. The Company may audit the Recipient's compliance with this Agreement.

8. Survival. The Recipient remains bound by these provisions unless the Company has rescinded it.

9. No Waiver. The Recipient understands and agrees that no failure or delay by the Company in exercising any right, power or privilege hereunder shall operate as a waiver thereof, nor shall any single or partial exercise thereof preclude any other or further exercise thereof or the exercise of any right, power or privilege hereunder.

10. Governing Law. This Agreement shall be governed by and construed in accordance with the laws of the [State or Commonwealth in which the siting proceeding is pending.]

11. Assignment Prohibited. Any assignment of the Recipient's rights, obligations or duties under this Agreement without the Company's prior written consent shall be void.

12. Entire Agreement. This Agreement contains the entire agreement between the parties concerning the protection of the CEII, and no modification of this Agreement or waiver of the terms and conditions hereof shall be binding upon the parties, unless approved in writing by each of them.

13. Severability. If any provision or provisions of this Agreement shall be held to be invalid, illegal or unenforceable, the validity, legality and enforceability of the remaining provisions shall not in any way be affected or impaired thereby.

IN WITNESS WHEREOF, the Recipient has executed this CEII Non-Disclosure Agreement as of the date set forth below.

Signature: \_\_\_\_\_

Name (please print):

Date:

Organization:

Address:

**SECTION II**

**CRITICAL ENERGY INFRASTRUCTURE INFORMATION (“CEII”)  
REQUEST FORM**

2. This form must be accompanied by an original signed Non-Disclosure Agreement, and should be used if you are a party or intervenor in a siting proceeding and are not employed by COMPANY or a federal or state agency. If you have already signed a CEII Non-Disclosure Agreement, please provide the date and purpose: \_\_\_\_\_
  
2. The undersigned requests the following information [describe in detail, including reason for request]: \_\_\_\_\_
  
3. The undersigned is:
  - a party or intervenor in [SHORT CAPTION OF PROCEEDING] having been admitted as such on \_\_\_\_\_.
  - an employee of COMPANY or an independent system operator or a regional transmission organization in North America
  - a state agency employee
  - a federal agency employee
  - an employee of the electricity reliability organization or regional entity
  - an employee of a transmission owner in this or another control area
  - a consultant of one of the entities listed above who has been retained to provide advice regarding the matter described in no. 5 below
  
4. Give the name of your employer and your title: \_\_\_\_\_
  
5. The undersigned represents warrants and agrees that the information is to be used solely for the following purpose [describe in detail]: \_\_\_\_\_
  
6. If you are a consultant, provide the name and contact information of an individual at the organization that has retained you so that we may verify your role: \_\_\_\_\_

I acknowledge that the foregoing is true and accurate, and agree to give COMPANY Service Company immediate notice if any of the foregoing is no longer true. I also consent to COMPANY and its affiliated companies sharing the fact that this request has been made and/or granted, and agree that COMPANY and its parent and affiliated companies shall have no liability to me in connection with this request.

Signature: \_\_\_\_\_

Name (please print): \_\_\_\_\_

Organization: \_\_\_\_\_

Business Address: \_\_\_\_\_

Email: \_\_\_\_\_

Phone: \_\_\_\_\_

Fax: \_\_\_\_\_

Date: \_\_\_\_\_