

Issued 06-Mar-06	 ELECTRIC OPERATIONS ORGANIZATION Construction Standard	C2010 Revision #0 Page 1 of 6
---------------------	---	---

****This Standard Supersedes BECo CS 2.7-4.25****

COLD SHRINK TERMINATION FOR JACKETED CONCENTRIC OR FLAT STRAP NEUTRAL CABLE, 25 KV AND BELOW

1.0 Bill of Materials

Equipment		Catalog ID
Cold Shrink Termination Kit - Quick Term III	15 kV, 1/0 str	9691*
	15 kV, #2str, #1 sol 25 kV, 1/0sol	9937*
	15 kV (2/0-300) 25 kV (#2-4/0)	9940*
	15 kV (500-1000) 25 kV (250-800)	13717
	25 kV (900-1750)	9948
#16 AWG Tinned Copper Wire		108
Aluminum Oxide Cloth, 150 Grit		585
Solvent Packet, Wet/Dry		5666
1" Plastic Tape		6374
2 Hole Terminal Lug	4/0 Cu	9636
	250 Cu	1399
	500 Cu	1403
	500 Al	9726
	700 Cu	1511
	750 Cu	1528
	1000 Al	1805

* Kit contains a spike terminal connector. Cat id 9940 contains a 2/0 spike connector.

2.0 Prepare Cable

2.1 Train the cable and cut it to the final installation length. Plan the final cut to allow adequate neutral wire for bonding.

2.0 Prepare Cable – cont'd

2.2 Prepare cable per Figure 1.

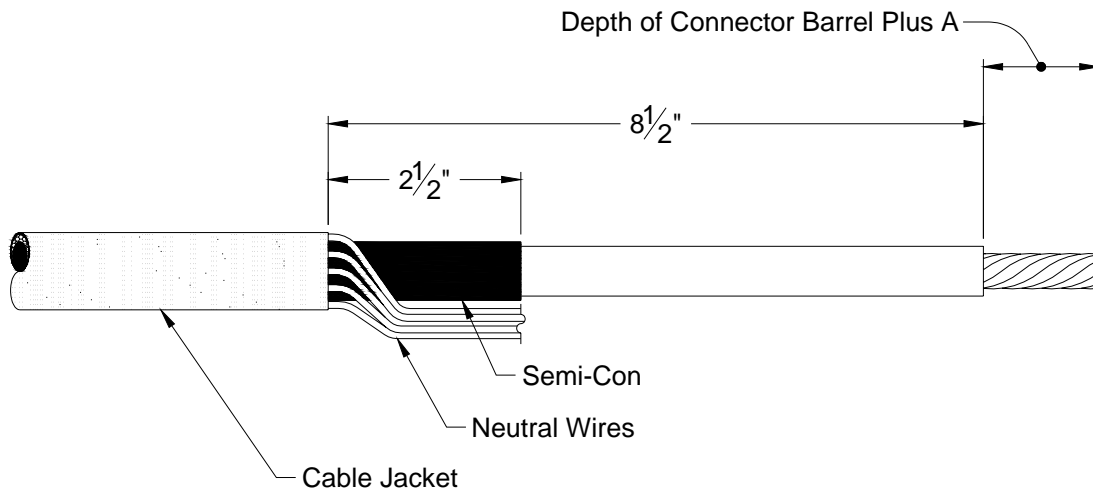

Figure 1 – Prepare Cable

Conductor	Dimension A
All Cu	1/4"
#2-350 MCM Al	1/4"
400 – 650 MCM Al	1/2"
750 -1000 MCM Al	3/4"

2.3 Apply mastic strip per Figure 2.

<p>Issued 06-Mar-06</p>	 ELECTRIC OPERATIONS ORGANIZATION Construction Standard	<p>C2010 Revision #0 Page 3 of 6</p>
-----------------------------	---	--

2.0 Prepare Cable – cont'd

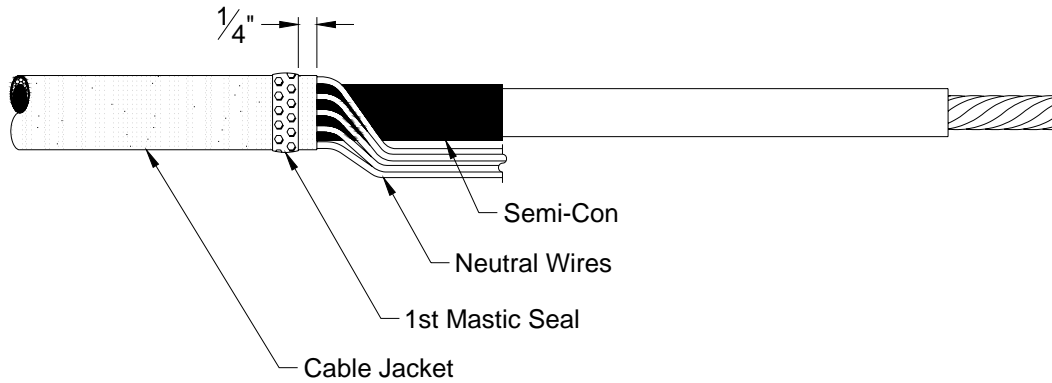

Figure 2 – Apply Mastic

- 2.4 Bend neutral wires back over jacket edge and press into mastic strip.
- 2.5 Secure the neutral wires to the cable 2" from jacket edge using plastic tape. Position tape with care, it also serves as a marker for positioning the termination.
- 2.6 Apply a second mastic strip over the neutral wires and previously applied mastic.
- 2.7 Compress neutral wires into mastic by over-wrapping seal strips with two layers of vinyl tape. **Be sure to cover all exposed mastic.** See Figure 3.

<p>Issued 06-Mar-06</p>	 ELECTRIC OPERATIONS ORGANIZATION Construction Standard	<p>C2010 Revision #0 Page 4 of 6</p>
-----------------------------	---	--

2.0 Prepare Cable – cont'd

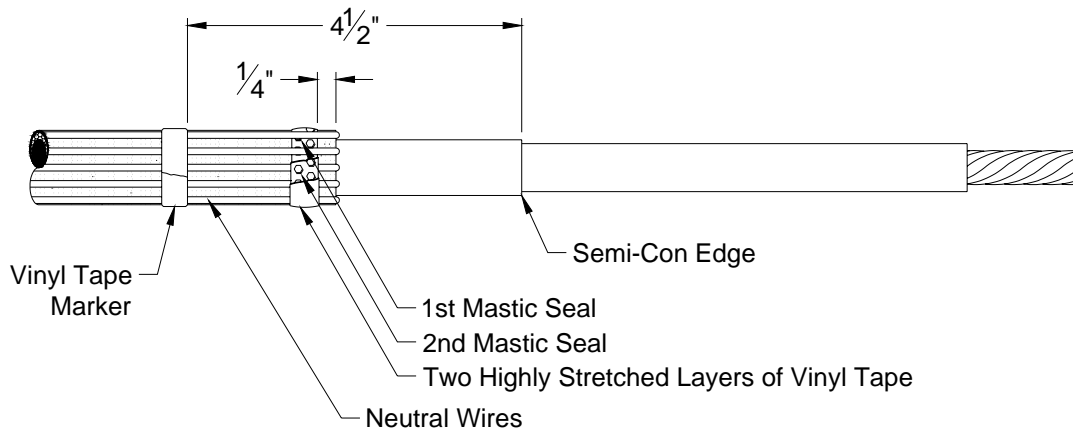

Figure 3 – Install Mastic and Marker Tape

3.0 Install Connector

- 3.1. Wire brush the exposed aluminum conductor. If the conductor is copper, brushing is not required.
- 3.2. Insert the conductor all the way into the barrel of the connector and crimp using a circumferential dies. Rotate each crimp 90°. Circumferential dies are preferred over nest/indenter dies or dieless tools.
- 3.3. Remove any excess inhibitor.
- 3.4. Using the aluminum oxide cloth and the solvent wet/dry pack(s), buff and clean the insulation. **Do not wipe from the black semicon towards the insulation because the insulation will become contaminated with conductive particles.**

3.0 Install Connector– cont'd

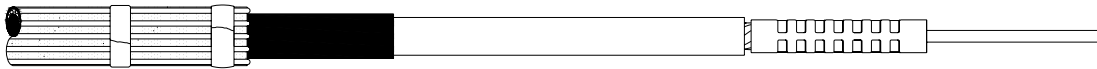
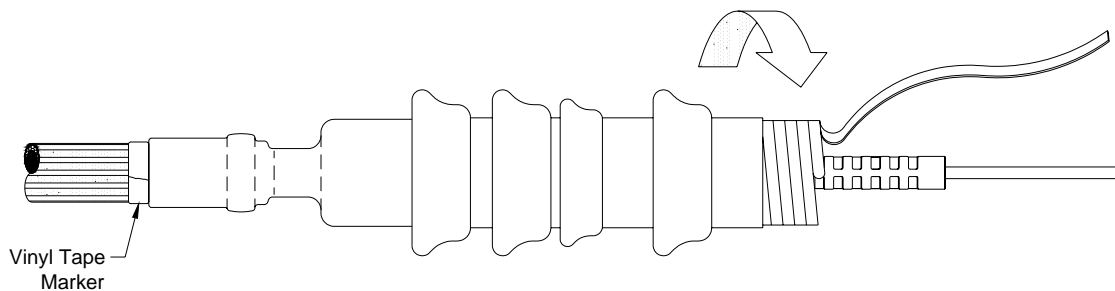



Figure 4 – Install Connector (spike terminal shown)

4.0 Install Termination

- 4.1 Slide the termination body over the end of the spiked terminal until the base is at the edge of the marker tape, per Figure 5.
- 4.2 Remove core, pulling while unwinding counter-clockwise starting with the loose end (Figure 5). Make sure the termination body, not the core, is butted up against the edge of the marker tape.



NOTE: The material being removed at this step is polypropylene and can be recycled with other  waste.

NOTE: Once the termination insulator has made contact over the mastic seal area, there is no need to continue supporting the assembly. Do not push or pull on the termination assembly while unwinding the core.

Figure 5 – Install Termination

4.0 Install Termination– cont'd

4.3 Connect neutral wires to system ground.

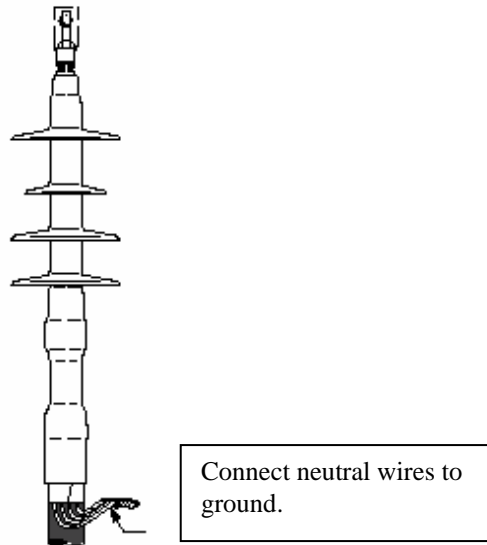

Figure 6 - Completed Assembly

Approved by: Elizabeth J. Leonard
Asset Strategy - Distribution
Technical Manager